

Una gamma completa per industria ed edilizia / A complete range for industry and building

# AIRO

# R12DC



**Piattaforme Aeree  
Semoventi**

• Piattaforma aerea cingolata • Tracked aerial work platform  
• Nacelle élévatrice chenillée • Raupen-Arbeitsbühne • Plataforma de oruga



AZIENDA CON SISTEMA QUALITA' CERTIFICATO ISO 9001:2000

Una gamma completa per industria ed edilizia / A complete range for industry and building

# AIRO



Concessionario  
Dealer  
Importateur  
Händler  
Concesionario

Piattaforme Aeree Semoventi

## R12DC

Descrizioni ed illustrazioni si intendono fornite a titolo indicativo e non impegnativo.  
Specifications are nominal and may be revised to reflect design improvements.  
En cas de nécessité les spécifications techniques peuvent être modifiées.  
Im Interesse einer technischen Weiterentwicklung können die Geräte jederzeit vom Hersteller entsprechend geändert werden.  
Las descripciones e ilustraciones descritas son orientativas y pueden ser modificadas.

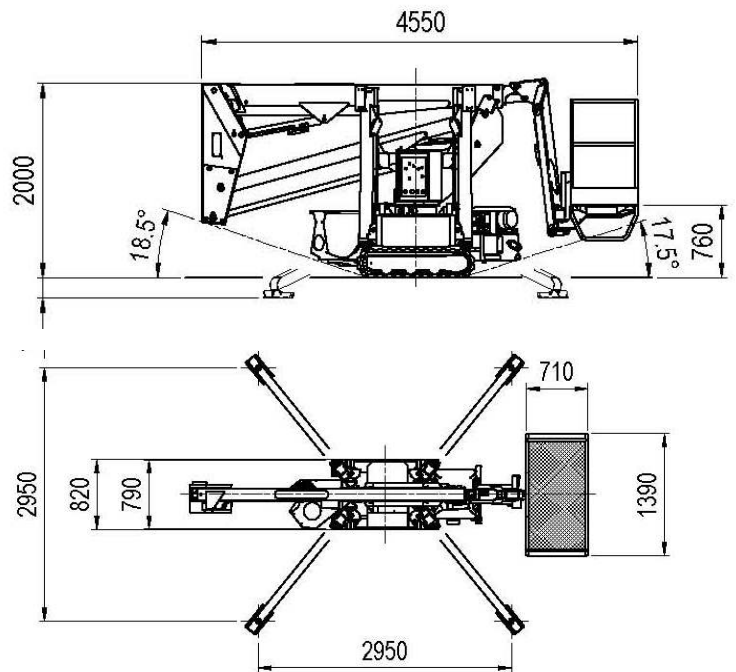
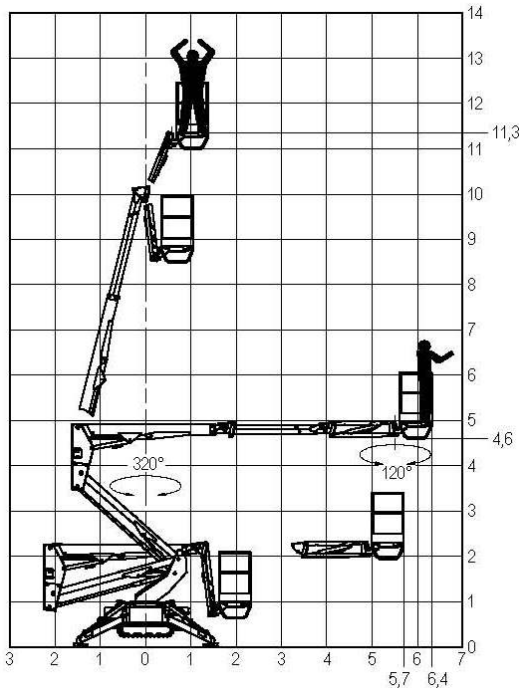

Altezza max. di lavoro	Working Height	Max. hauteur de travail	Arbeitshöhe	Máxima altura de trabajo	13300 mm
Altezza max. piano calpestio	Max. platform height	Max. hauteur de la nacelle	Max. Plattformhöhe	Altura máxima de la plataforma	11300 mm
Sbraccio max. di lavoro	Max working outreach	Déport max. de travail	Seitliche Reichweite	Extensión máxima de trabajo	6400 mm
Lunghezza macchina	Machine length	Longueur machine	Länge Maschine	Largura máquina	4550 mm
Larghezza macchina	Machine width	Largeur machine	Breite Maschine	Anchura máquina	820 mm
Larghezza cestello	Basket width	Largeur panier	Breite der Korb	Anchura de la cesta	1390 mm
Altezza macchina chiusa	Stowed machine height	Hauteur machine fermée	Hohe Eingezogene Maschine	Altura máquina cerrada	2000 mm
Area di stabilizzazione	Supporting Surface	Domaine stabilization	Abstützfläche	Superficies de apoyo	2950 mm x 2950 mm
Peso totale	Total weight	Poids total	Gesamgewicht	Peso total	2150 kg

### Allestimento Standard:

- Comandi proporzionali
- Cestello in alluminio per 2 operatori (portata 200 Kg) dotato di doppio accesso laterale
- Rotazione del cesto di 120°
- Rotazione torretta di 320°
- Articolazione jib +68° - 83°
- Linea elettrica ed aria compressa in piattaforma
- No celle di carico in quanto soddisfa il requisito di sovraccarico rinforzato (EN280:2001)
- Sistema diagnostica integrato
- Motore a benzina Honda IGX440 a controllo elettronico
- Elettropompa monofase 230V

### Standard Features:

- Proportional controls
- Aluminium basket for n.2 operators (capacity 200 Kg) equipped of double lateral access
- 120° cage rotation
- 320° turret rotation
- Jib +68° - 83°
- Electrical supply and compressed air on platform
- No-loading cells, as it answers to the reinforced overloading request (EN280:2001)
- Built in diagnostic system
- Piston engine Honda IGX440 with electronic control
- 230V monophase electro-pump

### Version Standard:

- Commandes proportionnelles
- Panier en aluminium par 2 personne (capacité 200 Kg) avec double-face d'accès
- Rotation panier 120°
- Rotation tourelle 320°
- Bras pendulaire +68° - 83°
- Ligne électrique et air comprimé sur le panier
- No capteurs de chargement parce que la nacelle satisfait l'exigence du surcharge renforcé (EN280:2001)
- Dispositif de diagnostic
- Moteur à essence Honda IGX440 à contrôle électrique
- Electro-pompe monophasé 230V

### Standardausstattung:

- Proportionalsteuerung
- Aluminiumkorb (Tragfähigkeit 200 Kg) mit zwei lateral Öffnungen
- Korbdrehung 120°
- Turmdrehung 320°
- Jib +68° - 83°
- Anschluss und komprimierte Luft auf der Plattform
- No Ladesensoren, weil es am die Frage von verstärkte Lastbergrenzer antwortet (EN280:2001)
- Integrierte Diagnose-System
- Benzin Honda IGX440 Motor mit elektronische Steuerung
- Elektropumpe monophase 230V

### Equipamiento Estandar:

- Mandos proporcionales
- Cesto de aluminio (capacidad 200 Kg) con doble apertura lateral
- Rotación de la cesta de 120°
- Rotación de la torreta de 320°
- Plumín +68° - 83°
- Línea eléctrica y aire comprimida en plataforma
- No limitador de carga, porque responde a la solicitud de sobrecarga reforzado (EN280:2001)
- Sistema de diagnosis integrado
- Motor a gasolina Honda IGX440 con mando electrónico
- Electrobomba monofásica 230V

AIRO by TIGIEFFE

TIGIEFFE

TIGIEFFE S.r.l. • Via Villa Superiore, 82  
42045 Luzzara (RE) - Italy  
Tel.: +39 0522 977365 (r.a.)  
Fax: +39 0522 977015



Web site:  
www.airo.it  
www.airo.com  
E-mail: info@airo.it

AZIENDA CON SISTEMA QUALITA' CERTIFICATO ISO 9001:2000